

NOTICE — The last day for appealing this decision is November 16, 1990

Committee of Adjustment

**DECISION OF COMMITTEE WITH REASONS
RE APPLICATION FOR MINOR VARIANCE**

Planning Act, 1983, c. 1, ss. 44 (8)

(a) Name of committee (a) Committee of Adjustment for the Corporation of the Town of Orangeville

(b) Name of applicant RE AN APPLICATION BY (b) Fred Temple

(c) Brief description LOCATION OF PROPERTY (c) 25 Bythia Street. Pt. Lot 6, Block 10, Plan 138

(d) As set out in application PURPOSE OF APPLICATION (d) Minor Variance to Zoning By-law No. 22-90 to allow a renovated deck on the south side of the house to extend to within 11 inches from the lot line.

WE, the undersigned, in making the decision upon this application have considered whether or not the variance requested was minor and desirable for the appropriate development and use of the land and that the general intent and purpose of the zoning by-law and the official plan will be maintained, or in the case of a change in a use of property which is lawfully non-conforming under the by-law as to whether or not this application has met the requirements of section 44 (2) of the *Planning Act*,

(e) Date of decision CONCUR in the following decisions and reasons for decisions made on the (e) 17 day of October 1990

DECISION:

THAT the request for a Minor Variance to permit the renovated deck to be built to within 11 inches from the lot line, **BE GRANTED SUBJECT TO THE FOLLOWING CONDITIONS.**

(f) State conditions to be satisfied before granting of consent **CONDITIONS** — This decision has been made subject to the following conditions: (f)

1. THAT the construction of the deck not impact the surface drainage from the abutting lot.
2. THAT no walls or roof are erected to enclose the deck.

(g) State reasons for decision **REASONS FOR DECISION: (g)**

The Committee felt the request was reasonable, and upon compliance with the conditions the request would be approved.

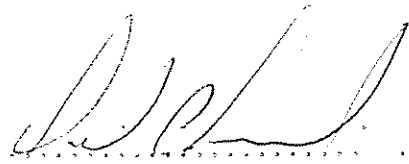
Signature of member of committee.

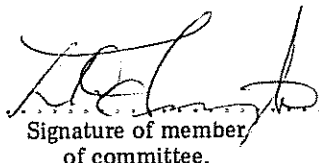
Signature of member of committee.

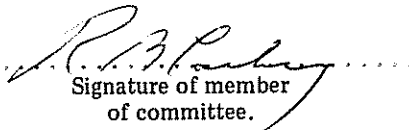
Signature of member of committee.

.....
Signature of member of committee. Signature of member of committee. Signature of member of committee.

CERTIFICATION
Planning Act, 1983, c. 1, ss. 44 (10)

I, Ann E. Armstrong

(h) Name of committee Secretary-Treasurer of the (h) Committee of Adjustment for the Corporation of the Town of Orangeville

....., certify that the above is a true copy of the decision of the committee with respect to the application recorded therein.

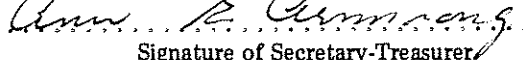
Dated this 25 day of October 1990 
Signature of Secretary-Treasurer

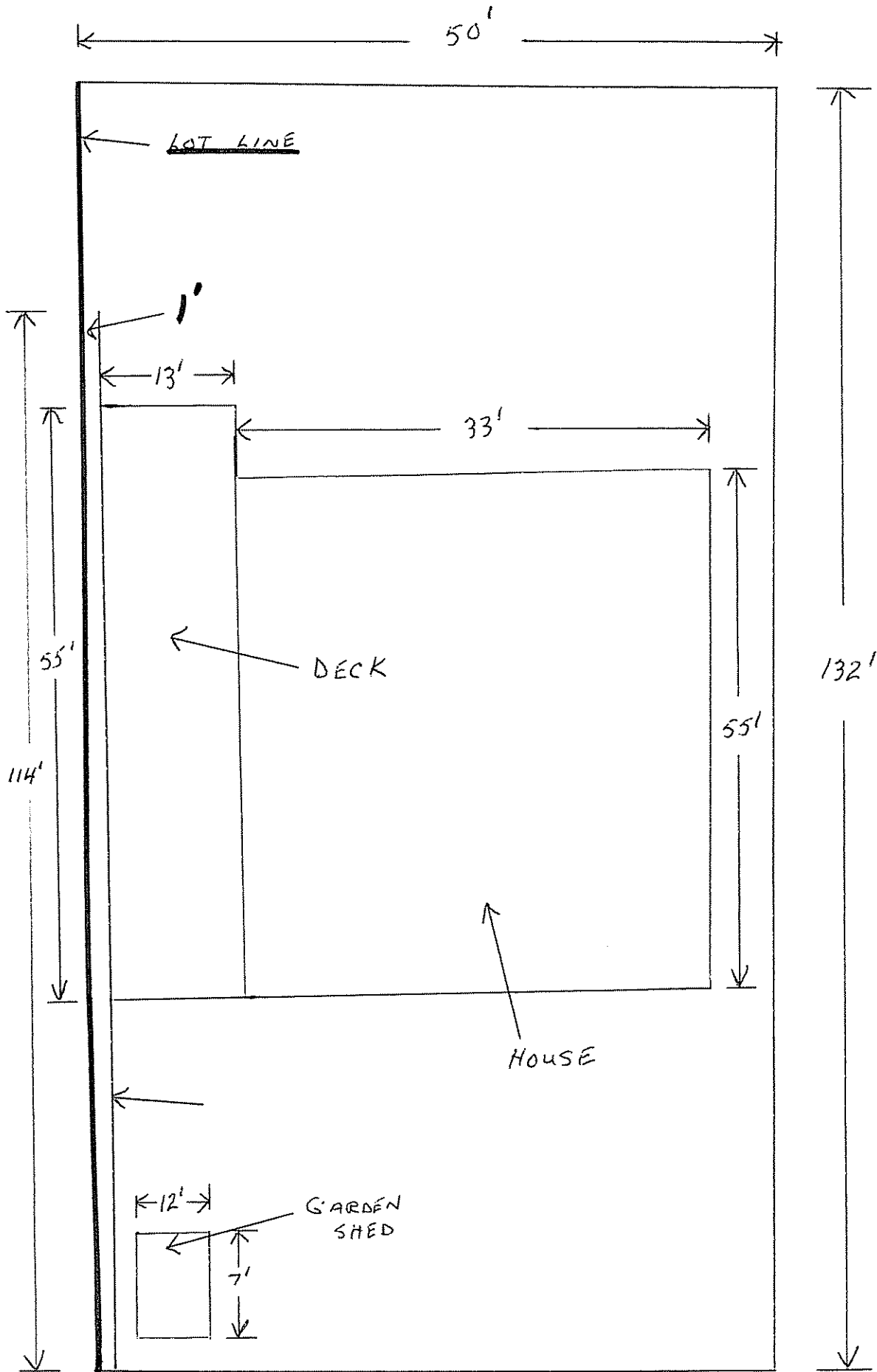

NOT
TO
SCALE